

# 2034vx /2034vxa Sandcarving System

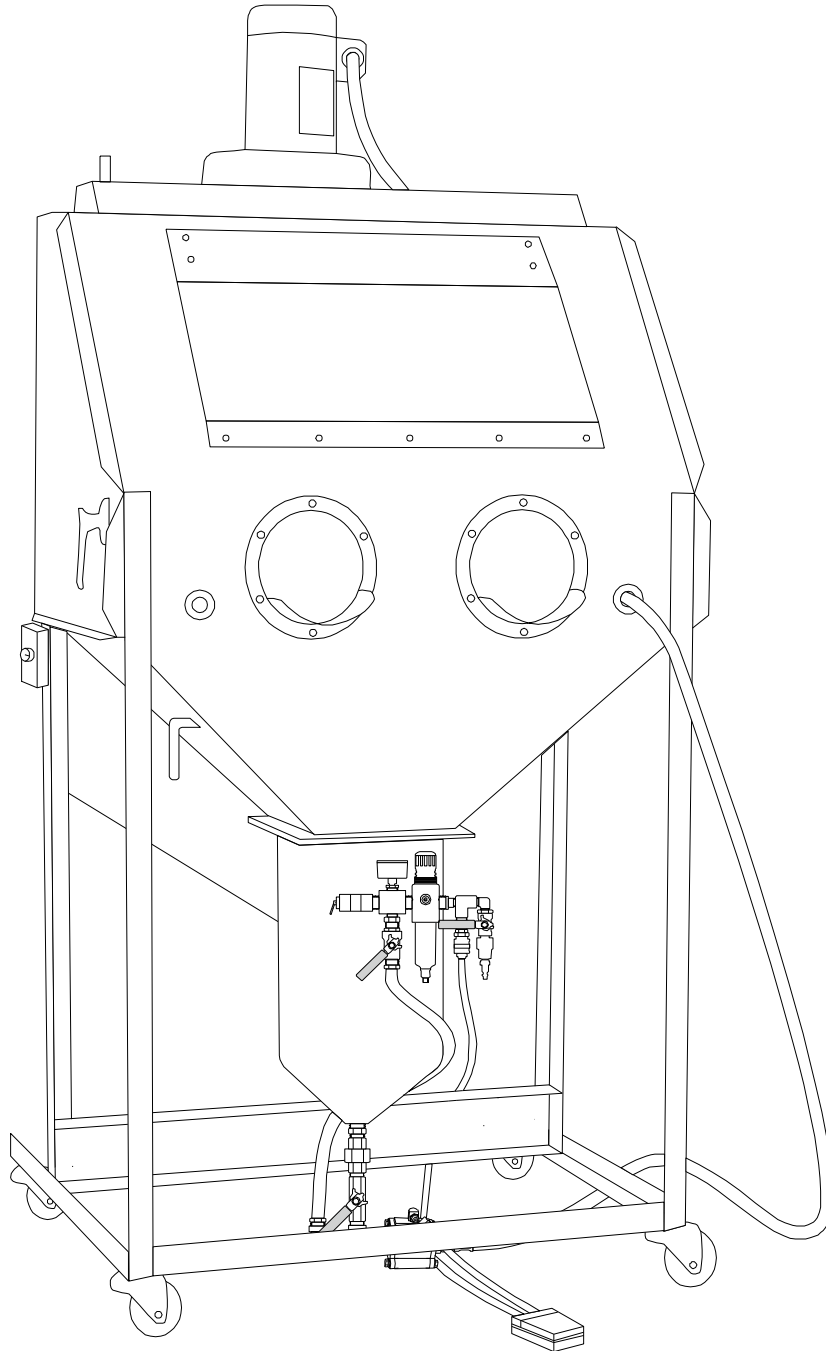



## **Table of Contents**

Section 1 - Safety Information

Section 2 - Setup Guide

Section 3 - Operation

Section 4 - Maintenance

# Reference Drawing

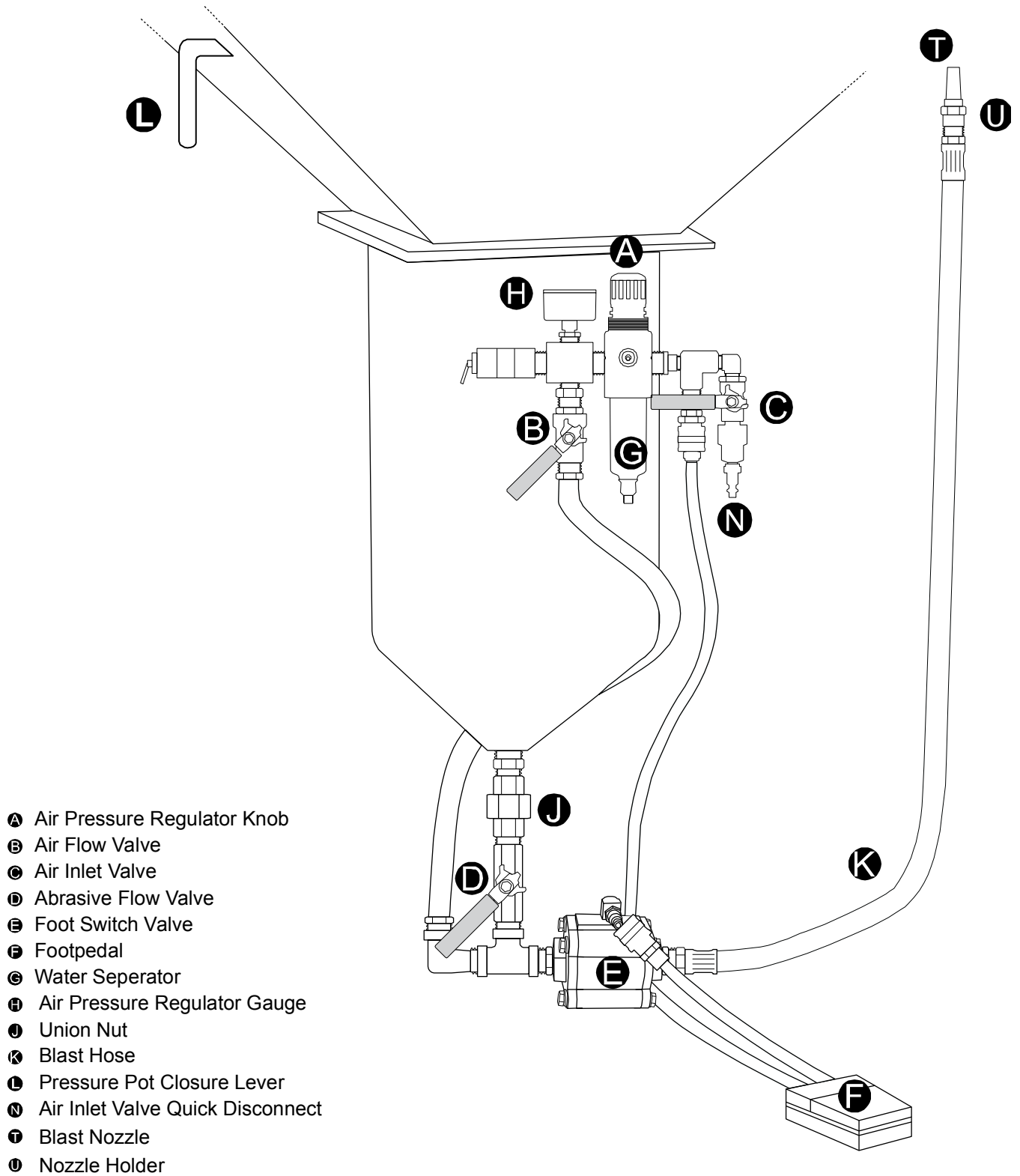

# SAFETY INFORMATION

**DO NOT attempt to operate this equipment until you have read and understand the potential hazards associated with operating this equipment and are able to follow all safety and operating procedures found in this manual.**

**Potential hazardous situations are identified whenever you see the following alert:**

**! WARNING**

## 1.0 SUMMARY OF POTENTIAL HAZARDS

This is a summary of primary hazards, read the entire manual to understand all of the potential hazards.

This equipment is designed for etching glass with aluminum oxide abrasive media. NEVER use silica sand or abrasive containing silica with this equipment. Breathing dust from silica sand may cause silicosis, a fatal lung disease.

### 1.1 Electrical

1.1.1 Injury or death caused by electrical shock or fires caused by electrical shorts can occur if electrical outlets are not properly grounded and do not have the proper circuit breaker protection of 15 amps. Make sure the electrical outlet is grounded and is connected to a properly working 15 amp circuit breaker. DO NOT use extension cords to connect this equipment.

1.1.2 Always unplug power when doing repairs, maintenance or replacing lamps.

### 1.2 Lighting

1.2.1 The Lighting fixtures inside the cabinet will get very HOT, especially the glass lens. Touching these fixtures while or shortly after, the machine has been running may cause severe burns. When replacing bulbs do not exceed 100 watt bulbs.

1.2.2 The Lighting fixtures inside the cabinet have seals to help keep dust out but are not explosion proof. Do not blast materials that may produce combustible dusts. Never use flammable solvents inside the cabinet.

### 1.3 Dusts

1.3.1 Prolonged breathing of dusts produced by blasting media and materials removed by blasting may result in serious respiratory injury or death. Health risks may vary with type of abrasive media and materials that are removed by blasting. NEVER use this equipment to blast materials that may produce toxic dusts such as lead. ALWAYS wear NIOSH approved respirators for ANY activity where you may be in contact with airborne dusts.

1.3.2 Abrasive media and dusts may cause irritation to the skin. Wear 18 mil rubber or latex gloves such as the ones provided with the cabinet when blasting and whenever the abrasive may come in contact with your skin.

1.3.3 Abrasive media and dusts may cause irritation to your eyes. Protective eye goggles should be worn whenever handling the abrasive or cleaning the cabinet.

1.3.4 ALWAYS shut off main air supply "lever C" at the end of each day. If the valve is left on and the air compressor supply shuts off at night the pot will depressurize and automatically open. When the air compressor comes back on the next day, air will run through the pot and abrasive and dust will blow out through the arm holes of the cabinet creating a hazardous condition of dust in the air.

**1.4 Abrasive Blasting Medias** – NEVER use silica sand or abrasive containing silica with this equipment. Breathing dust from silica sand may cause silicosis, a fatal lung disease. We recommend and supply with your cabinet, 150 grit Brown Aluminum Oxide, MSDS information is provided in your information package.

**1.5 Vortex Dust Collector -** The HEPA dust filter bags inside the dust collector will require replacing when they become worn or damaged. Accumulation of dust inside the dust collector compartment is evidence of bag damage. The dust collector compartment should be inspected periodically. Dust escaping bags will exit exhaust blower creating a possible respiratory hazard. Never Wash bags to reuse always replace with new bags.

## **1.6 Pressure Pot**

**1.6.1** Failure to follow the procedures in this manual could result in serious injury or death from the sudden release of compressed air. NEVER attempt to open the pressure pot closure mechanism using the Pressure Pot Closure Lever (L). This could cause a sudden UNSAFE release of compressed air. The pressure pot opens automatically when the pot is depressurized. Never do maintenance on any component of the pressure pot while the pot is pressurized. Never apply more than 100psi of incoming air pressure from the air compressor to the system. SET incoming air pressure from air compressor between 80psi to 90psi. Set blasting pressure regulator on the pot to desired blasting pressure, normally between 25 psi - 35 psi.

## 2.0 SET-UP INSTRUCTION

### 2.1 Requirements for Set-up

#### 2.1.1 Tools Needed:

- ¾" open end wrench, ¾" socket wrench, or crescent wrench.
- Box knife

**2.1.2 Electrical Requirements:** (Grounded) 110-120 Volt 60 Hz 15 AMP circuit breaker

#### 2.1.3 Compressed Air Requirements:

Minimum Required CFM (Cubic Feet per Minute)  
6.0 – 8.0 at 90 psi.  
Average blasting pressure @ 35psi = 5.46 CFM

### 2.2 Delivery & Unpacking Instructions

## ! WARNING

**This equipment can weigh in excess of 500 lbs. To avoid injury, use proper lifting and moving equipment.**

**2.2.1** This equipment is shipped on a pallet and should be removed from the truck with a forklift or with the use of a lift gate.

**2.2.2** Before removing the equipment from the shipping pallet remove the outer packing and recycle.

**2.2.3** Remove all the contents inside the cabinet.

### 2.3 Cabinet Inspection

**2.3.1** Before removing the equipment from the shipping pallet inspect the cabinet for the following:

1. External damage to the motor, viewing glass, power connections, switches, handles, and the pressure pot.
2. Check lighting fixtures inside the cabinet to make sure they are tight and have not vibrated loose in shipping.

## ! NOTICE

If there are any external or internal damages to the equipment **it must be noted on the carrier's bill of lading**. Contact Rayzist customer service at 1-800-729-9478 immediately to process a damage claim. Keep the packaging intact. Take photos of damage. Receiver accepts all responsibility once the bill of lading is signed.

### 2.4 Parts Inventory

Make sure you have received all the following items with your cabinet.

- Mask Making Kit (if purchased with the cabinet).
- 50 lb 150 grit Aluminum Oxide
- HD Blast Hose (K) with 3/32" Nozzle and holder.
- Abrasive Recovery Bucket (2 gallon plastic bucket)
- Foot Pedal Assembly (F) with hoses.
- Dust Mask
- Blasting Gloves (18 mil)
- 2034VXA Manual

## 2.5 Removal from Pallet.

### **! WARNING**

**Removal of the cabinet from the pallet requires at least two people.**

2.5.1 The cabinet is bolted to the 4x4 blocks mounted on the pallet. Locate the bolts and remove with  $\frac{3}{4}$  inch opened end or socket wrench.

2.5.1.1 With two people slide the cabinet off from one side so two of the casters will touch the ground at the same time.

2.5.1.2 Once the first two casters are touching the ground carefully slide the remaining part of the pallet out from under the cabinet.

## 2.6 Footswitch Valve and Blast Hose Setup

2.6.1 Locate the Foot Switch Valve (E) and blast hose (K) assembly in box at bottom of cabinet.

2.6.2 On some shipments it is required to attach pipe union nut (J) to fitting at the bottom of the pressure pot. Use wrench to tighten.

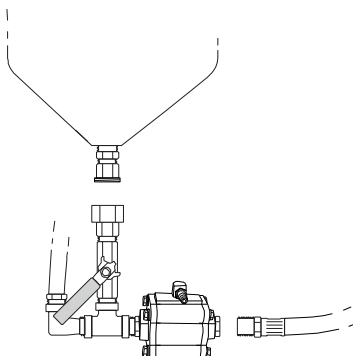

## 2.7 Foot Petal Connection

The foot petal (F) has a short hose and a long hose with quick disconnect fittings. Connect the short hose to quick disconnect fitting on footswitch valve (E). Connect the long hose to the quick disconnect fitting located between water separator (G) and the air inlet valve (C).

## 2.8 Dust Bag Installation

2.8.1 Remove (by pulling) rubber plug from bottom hole. (The rubber plug must be used if no bag is installed).

### 2.8.2 2034vx:

2.8.2.1 Remove metal ring clamp.

2.8.2.2 Install bag over disk with several inches of bag above the disk.

2.8.2.3 Attach ring clamp over bag and disk and lock clamp. A good portion of the bag should be laying on the floor.

### 2.8.3 2034vxa:

2.8.3.1 Install bag over disk with several inches of bag above the disk.

2.8.3.2 Use a zip tie to secure the bag tightly around the disk.

2.8.4 When cabinet power is turned on the bag should collapse, indicating that it is sealing the dust collector. If the bag does not collapse then the bag must be replaced.

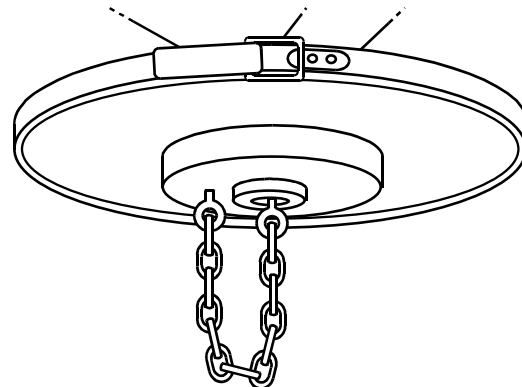

2034vx Model

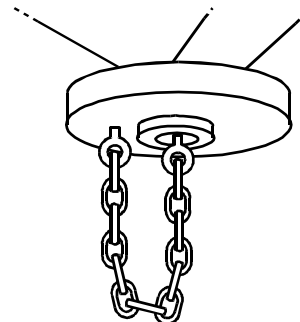

2034vxa Model



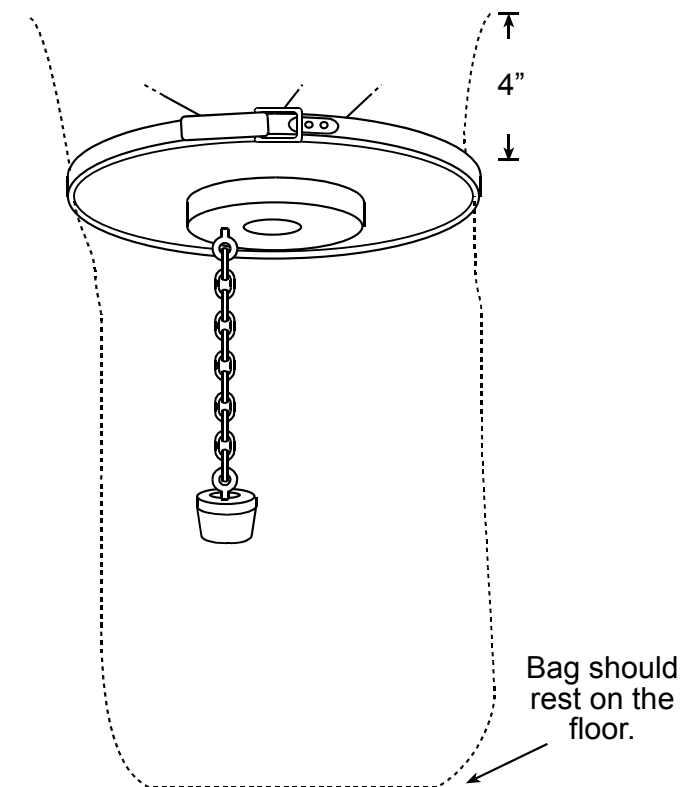

## 2.9 Electrical Connection

2.9.1 Plug cabinet into a grounded 110-120 volt electrical outlet with 15-amp circuit breaker.

2.9.2 . Turn on power-switch to test proper function of motor and lights

2.9.3 Check plastic dust bag and make sure it is collapsing when the dust collector is on.

## 2.10 Exhaust Connection

2.10.1 The exhaust blower is fitted with a sheet metal elbow for the purpose of directing the exhaust in an upward direction. Installation of an exhaust vent is optional for the purpose of reducing noise or exhausting dusts resulting from damaged or worn dust bags. Installation of exhaust vent should be done by a licensed contractor to make sure there is no restriction of airflow that would affect the proper function of the dust collector. Exhausting through a long vent pipe may require an additional exhaust fan installed at the point the vent exits the building.

## 2.11 Adding Abrasive Media

The system has been shipped without the abrasive media in the pot. Turn the dust collector on, place unopened 50lb bag of 150 grit aluminum oxide abrasive into the cabinet. Slit the center of the bag open. Close the side door and empty the bag using the front armhole access. After the dust has cleared remove the bag from the cabinet.

## ! NOTICE

The abrasive media will break down over time causing more dust in the cabinet and slower blasting. New abrasive should never be added to old abrasive. Instructions for removing worn abrasive and adding new abrasive are covered in the Operation Manual. DO NOT over fill the pot with more than 50 lbs of abrasive; this may prevent the pot closure cap from sealing.

## 2.12 Air Compressor Requirements

**NOTE: Customer Supplied and used only for the Cabinet.**

The following or similar items are recommended for moderate cabinet use. [www.grainger.com](http://www.grainger.com) or call 800 225 5994

### 1. Air Compressor

Grainger's Model: # 4YN50

2 horsepower, High Performance Cast Iron Air Compressor

Free Air CFM @ 90 PSI: 5.5

Free Air CFM @ 135 PSI: 4.9

Volts 60 Hz: 115/230

Amps: 15/7.5

Tank Capacity (Gal): 26

### 2. Water Trap

### 3. Air hose

## 2.13 Dedicated Air Compressor Set-up

---

### ! NOTICE

---

DO NOT connect air to the cabinet until you are instructed to do so in the operation manual. Follow all procedures found in compressor manufacturers literature.

---

**2.13.1** It is highly recommended that you install a water trap to the compressor. Moisture getting into the abrasive can cause the pressure pot to clog and prevent the flow of abrasive. If you are using a water trap, install it to the output connection on the compressor. This connection is generally after the air pressure regulator.

**2.13.2** Connect air hose to water trap.

**2.13.3** The end of the air hose should have a quick disconnect coupling that will connect to the fitting (N) on the pressure pot.

**2.13.4** Turn on the compressor and let it fully charge with air but DO NOT connect the air hose to the cabinet yet.

**2.13.5** Air compressors generally have an output regulator and two air pressure gauges. One gauge is to indicate the pressure in the tank and the other is the output pressure the customer sets. Set the output pressure regulator to 90 psi.

## 2.14 Height Adjustment

**2.14.1** The 2034vx Adjustable Sandcarving system has an electrically powered height adjustment switch. Height measured at the arm holes can be adjusted from 39 to 53 inches. The adjustment switch is located on the left side of the cabinet behind the access door. The adjustment switch should be left in the middle (stop) position unless the cabinet is being raised or lowered. Make sure to avoid any pinch point, and ensure there is proper clearance when raising and lowering the cabinet. Cabinet should automatically stop at the minimum and maximum heights.

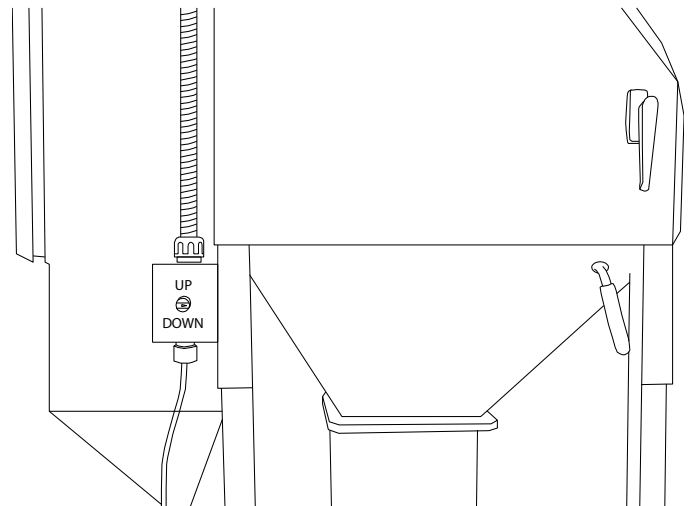

## 3.0 OPERATING INSTRUCTIONS

### ! NOTICE

When a ball valve handle is parallel to the valve or plumbing, the valve is wide open. When a ball valve handle is perpendicular to the valve, it is completely closed.

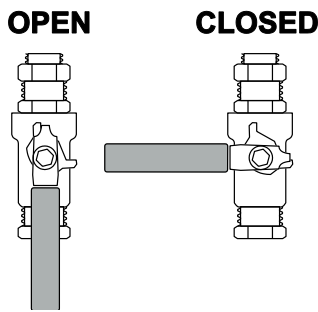

**3.1 Pressure Pot Settings:** The Pressure Pot has two adjustment ball valves that can regulate the abrasive/air flow mixture. The standard settings for the pressure pot should be made as follows:

3.1.1 Set Abrasive Flow Valve (D) at approximate half way open or approximately 45° angle.

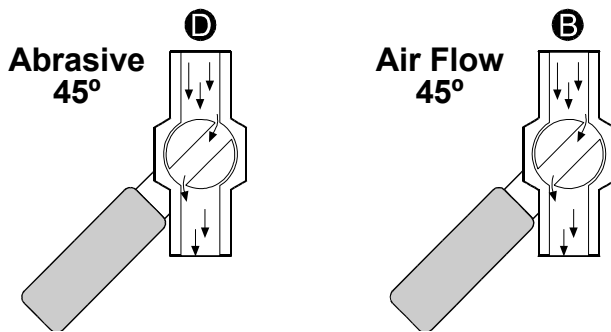

Set Air Flow Valve (B) approximately half way open or at 45° angle. Adjustments will need to be made as wear occurs to Blast Hose (K) and Blast Nozzle (T).

### ! NOTICE

Abrasive Flow Valve (D) usually does not require adjustments from the 45 degree position unless there are drastic pressure changes, or larger nozzle orifices are used.

## 3.2 Connecting Air to Cabinet

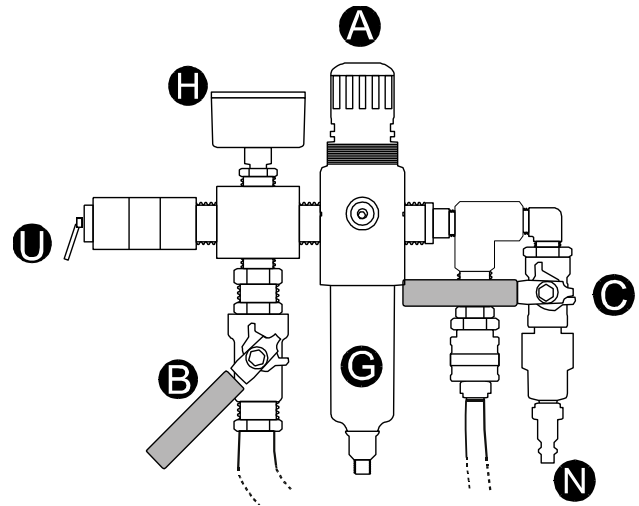

3.2.1 Before connecting the air hose from the compressor to the pot, make sure the Air Inlet Valve (C) is in the “OFF” position (horizontal) and the air compressor has been set up according to instructions found in the Rayzist setup guide.

3.2.2 Connect the compressor air hose to the Air Inlet Valve Quick Disconnect Plug (N) but DO NOT turn the air inlet valve (C) to the on position yet.

### ! NOTICE

The pressure pot is equipped with a safety relief valve (U). If the pressure from the air regulator (A) rises above 100 psi the relief valve (U) will pop open and release air. Since your incoming air is to be adjusted to 80-90 psi this should never happen. This is a safety device and should never be used to drain air from the pressure pot. Draining air from the pot using this valve will cause abrasive to enter and damage the regulator.

### ! NOTICE

The air pressure regulator (A) sets the blasting pressure, which can be seen in gauge (H) only after the pressure pot has been pressurized. It is factory set at 30 psi.

### 3.3 Pressurizing the Pressure Pot

The pressure pot opening is located inside the cabinet below the metal grate. The pressure pot closure cap is attached to a linkage, which is movable from the pressure pot closure lever (L) on the left side of the cabinet. The purpose of the lever and linkage is to lift the pressure pot closure cap upward to contact the pressure pot rubber seal located at the top of the pot. While holding the cap in the up position with lever (L) the air is turned on, this fills the pot, and presses the cap securely against the pressure pot rubber seal, sealing the pot and pressure inside. When the cap is in the down position there is a gap between the cap and the seal, which allows the abrasive from blasting to re-enter the pot.

---

## ! WARNING

---

Ensure that the Blast Hose (K) is in the cabinet at all times when the pressure pot is under pressure.

---

**3.3.1** Locate the Pressure Pot Closure Lever (L) and move it back and forth rapidly several times to shake off any abrasive that may be sitting on top of the closure cap.

**3.3.2** Now push the lever away from you to lift the pressure pot closure cap against the rubber seal. While holding the lever firmly in this forward position, open the Air Inlet Valve (C). Count 3 seconds and then release the Pressure Pot Closure Lever (L). The pot should be closed and pressurizing at this point. The Air Pressure Regulator Gauge (H) should rise to the factory pre-set blasting pressure of 30 psi.

**3.3.3 NOTE:** If you hear air escaping inside the cabinet, turn off lever (C) and try again. If for some reason you cannot get the pressure pot closure cap to seal, call Rayzist and ask for technical help.

### 3.4 Adjusting Blasting Pressure.

**3.4.1** After pressurizing the pot the pressure regulator gauge (H) should read about 30 psi. If the gauge has a different reading make an adjustment as follows: Unlock the Air Pressure Regulator Knob

(A) by pulling upwards. Twist clockwise to increase blast pressure or counter clockwise to decrease blast pressure. Set regulator to desired pressure, and then press down to lock the knob.

### 3.5 Adjusting Abrasive and Air flow

**3.5.1** Turn on the dust collector and lights and check the plastic dust bag on the dust collector to make sure it is collapsing; this indicates it is properly installed and has sealed the dust collector opening.

---

## ! NOTICE

---

When first stepping on the Foot Pedal (F), you may experience a thick burst of abrasive media from the blasting tip, which should smooth out to a constant flow of abrasive and air. This occurs when Abrasive Flow Valve (D) is open too far. When starting to blast you should hold the blasting tip away from the item you are blasting until abrasive media is flowing smoothly.

---

**3.5.2** Put on the rubber blasting gloves and hold the Blast Hose (K) and have the tip pointing downwards towards the grate about 6" to 8" away. Step on the foot pedal and watch the flow of abrasive as described above.

---

---

## ! NOTICE

---

Air Flow Valve (B) adjusts how much air pushes the abrasive through the Blast Hose (K). Less air flow = more abrasive. More air flow = less abrasive.

---

**3.5.3** If necessary adjust Air Flow Valve (B) to achieve the proper balance of abrasive and air. If there is too much abrasive open valve more, if not enough close the valve slightly. If the abrasive is pulsating between thick and thin, you may need to slightly close the Abrasive Flow Valve (D).

### 3.6 Sandcarving

**3.6.1** Turn on cabinet power switch located above the right cabinet access door; the dust collector and lights should both begin operating.

**3.6.2** Use (provided) rubber gloves before blasting. (18mil or thicker rubber or latex safety gloves can be purchased from a local hardware store.).

3.6.3 Place item to be etched inside cabinet. Hold Blast Hose (K) in hand (like a pencil).

3.6.4 By pressing on the Foot Pedal (F), the air/abrasive flow starts; by letting off the Foot Pedal, the air/abrasive flow stops.

3.6.5 Depress Foot Pedal (F), holding Blast Hose (K) 3" - 4" away from item, use slow sweeping motions across image area to be etched.

---

## **! NOTICE**

---

Always depressurize the pressure pot when you are done blasting for the day. It is not necessary to do this if you are intermittently blasting through out the course of the day but should always be done when you are done blasting for an extended period of time. Instructions for depressurizing the pot are covered below.

---

### **3.7 Depressurizing the Pressure Pot and recycling the abrasive.**

---

---

## **! NOTICE**

---

Always use the following procedure when you are finished blasting or you run out of abrasive.

---

## **! WARNING**

---

NEVER attempt to open the pressure pot closure cap using the Pressure Pot Closure Lever (L). This could cause a sudden UNSAFE release of compressed air. The pressure pot opens automatically when the pot is depressurized.

3.7.1 After you are done blasting, or you run out of abrasive during blasting, keep the dust collector turned on and then turn off the Air Inlet Valve (C). Then depress the foot pedal until the pot is depressurized. When all the air pressure is exhausted the pot closure cap will automatically open and the abrasive that has collected in the bottom of the cabinet will flow back into the pot. You can get additional abrasive to fall back into the pot by tapping on the outside of the cabinet just above the pot. The pot is now filled again and is ready for the next time you blast.

---

## **! NOTICE**

---

If for some reason, the pot closure cap does not open the pot after the Air Pressure Regulator Gauge (H) has reached zero, you can open the closure manually by pulling the Pressure Pot Closure Lever (L) towards you. NOTE: for safety reasons this should never be done unless the Air Pressure Regulator Gauge (H) reads zero and the main air supply is disconnected.

---

## **! WARNING**

---

Never leave the pot pressurized over night. If valve ( C ) is left on and the air compressor supply shuts off at night the pot will depressurize and automatically open. When the air compressor comes back on the next day, air will run through the opened pot and abrasive and dust will blow out through the arm holes of the cabinet creating a hazardous condition of dust in the air.

## 4.0 MAINTENANCE

### ! WARNING

ALWAYS depressurize the pot before doing maintenance.

ALWAYS unplug the cabinet from power before doing maintenance.

ALWAYS wear respirators, eye protection and gloves if you will be exposed to abrasive media and airborne dusts.

### 4.1 Daily Maintenance

4.1.1 Normally water drains from the water separator automatically. If excess water is building up in the water separator (G) drain the water using the manual drain spout. While under pressure turn counter-clockwise to open, and then clockwise to close. Also drain water from the air compressor tank as needed by following the manufacturer's instructions.

4.1.2 With dust collector turned off, shake dust collector bags using shaker lever (M) at the top of dust collector. This is required to keep dust collector working properly. When shaking you should see dust dropping into the plastic dust collection bag at the bottom of the dust collector hopper.

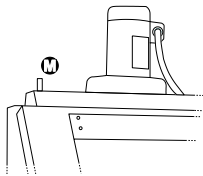

### Periodic Maintenance

### 4.2 Dust disposal bag replacement.

### ! NOTICE

Only use 4 or 6 mil poly bags that are 18 Inches by 36 to 40 Inches long. Bags are available through Rayzist or your local plastic bag company.

### ! NOTICE

It is normal for some of the abrasive media to be found in the dust disposal bag. Never recycle materials from the dust collector back into the pressure pot.

4.2.1 Pinch or twist the bag tightly closed underneath the Ring Clamp then open the clamp by opening the safety lock and then the clamp lever. Tie off the bag and discard.

4.2.2 Slide a new bag through the Ring Clamp and fold about 3 inches of bag material over the ring. Open ring clamp lever and slide bag and ring over PVC disk. Close ring lever and secure safety lock.

4.2.3 Turn on dust collector and make sure bag collapses and is sealing the dust collector.

4.3 **Abrasive Sifting Screen Cleaning:** Looking inside the cabinet through the grate to the bottom of the cabinet, and top of the pressure pot opening, you will see a wire screen material. This screen material is designed to prevent unwanted materials such as tape or stencil material from entering the pressure pot. Periodically the build up of these materials will need to be removed. This is best done at the beginning of a day before the pressure pot is pressurized. Start by removing the steel grate from the inside of the cabinet. Next, find an item you can use to push any remaining abrasive through the screen so that all that remains on top on the screen are the unwanted materials. Use a shop-vac with a long vacuum extension and vacuum the unwanted materials out of the cabinet. Replace the grate.

### 4.4 Abrasive Removal for Disposal

4.4.1.1 Abrasive life expectancy may be 15 to 20 hours of blasting. Worn abrasive does not cut as fast as new abrasive and will generate more dust inside the cabinet during blasting.

---

## ! NOTICE

---

DO NOT add new abrasive to worn abrasive. Always replace worn abrasive with new abrasive using the following procedures. Always wear respiratory protection for this procedure.

---

4.4.1.2 Remove the Blast Nozzle (T) from the Blast Hose (K). Place the abrasive disposal bucket, with lid attached, into the cabinet and close the door. Turn on the dust collector. Place the nozzle of the blast hose into the abrasive disposal bucket. Set the Air Pressure Regulator Gauge (H) to 20 PSI by adjusting Air Pressure Regulator Knob (A). Turn off the Air Flow Valve (B). Press the Foot Pedal (F) until the bucket is full or the pressure pot is empty. Put worn abrasive in plastic bag and dispose of according to local regulations. Repeat as necessary until abrasive is completely emptied.



### 4.4.2 Adding New Abrasive

4.4.3 With the dust collector on, place unopened 50lb bag of abrasive into the cabinet. Slit the side of the bag open allowing the abrasive to flow into the bottom of the cabinet. Close the side door and empty the remainder of the bag using the front armhole access. After the dust has cleared remove the bag from the cabinet.

## 4.5 Viewing Glass Replacement

---

## ! WARNING

---

Edges of glass can be sharp and cut through your skin. Wear protective gloves when handling the glass.

---

4.5.1.1 The window consists of two 12" x 24" panes of glass, the outer double safety laminate (replacement not required), and the inner 1/8" thick single strength glass. The inner single strength glass will get frosted over time and will impair visibility.

---

## ! NOTICE

---

12" x 24" x 1/8" thick single strength window glass can be purchased from a local glass retailer.

---

4.5.1.2 To replace: loosen (but do not remove) the five window bracket screws on the bottom of the window and the four bracket screws on the top of the window. Carefully slide both panes of glass out to the right or left of the cabinet.

4.5.1.3 Replace the single strength glass pane and slide both back into the window brackets. Tighten five bottom bracket screws so that the bracket is firmly against the face of the cabinet. Tighten 4 bracket screws on top until glass is slightly compressing the foam seal under the glass. DO NOT over tighten these 4 screws.

## 4.6 Replacing FSV Sleeve (R)

---

## ! WARNING

---

Disconnect air and depressurize pot before replacing the Tube Sleeve.

---

4.6.1.1 The sleeve will fail when a small hole is worn through the sleeve. Evidence of this is that the foot switch will no longer turn off the flow of abrasive and air.

4.6.1.2 To replace sleeve, Disconnect air and DEPRESSURIZE the pressure pot according to the instructions in operation manual.

4.6.1.3 Remove the eight bolts to disassemble both sides of the Foot Switch Valve Assembly (E).

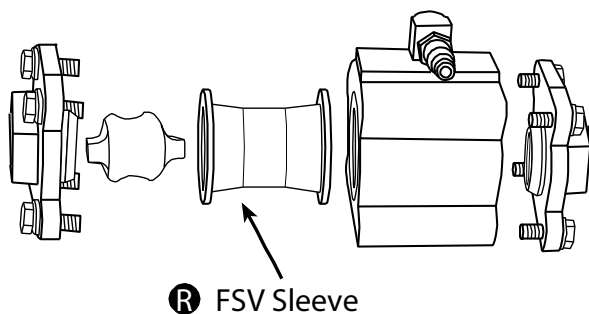
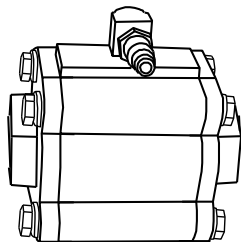

Footswitch Valve Assembly Illustration

4.6.1.4 Replace the sleeve and re-install bolts. After hand tightening the bolts, tighten them with a wrench to properly seal the gasket.

#### 4.7 Replacing the Blast Nozzle (T)

4.7.1.1 Replace when the Blast Nozzle (T) orifice exceeds 1/8". A large orifice may cause damage to the mask, and require a higher rate of CFM demand from the air compressor. Nozzle wear can be checked using a drill bit of the appropriate size.

#### 4.8 Long Term Maintenance

Several items may need replacement after significant machine operation. The following is a list (instructions for these are supplied with the replacement parts).

4.8.1 Blast Hose (K).

4.8.2 Weather Strip Seal on doors.

4.8.3 Light bulb replacement – Always Turn off unplug power from the unit. Do not exceed 100 watt bulbs.

4.8.4 Dust collector dust bags – The dust collector bags are treated with a special non-stick liner and should operate with a long life as long as daily and periodic maintenance is followed. Replacement is required if any tears develop in the bag allowing dust to bypass collector and exit exhaust vent. Periodically check in dust collector chamber. Dust accumulated in the bottom surface indicates the bags are worn and need replacing. Over time the dust collector bags may need to be replaced if dust in the cabinet becomes excessive and is obstructing visibility.

4.8.5 After long term use the Foot Pedal and air hoses will need to be replaced.

#### Keep spare parts on-hand

| Part                             | Part # |
|----------------------------------|--------|
| Heavy Duty Blasting Hose (K)     | HDHBLK |
| Brass Nozzle Holder              | NZHLD  |
| Carbide Nozzle (T) – 3/32"       | NZ32   |
| Roc Nozzle, composite – 3/32"    | ROC32  |
| Aluminum Oxide Abrasive 150 Grit | AO150  |
| Silicon Carbide 150 grit         | SC150  |
| Foot Switch Valve Repair Kit (R) | FSVKIT |
| Std Foot Pedal w/ hoses (F)      | FPRS   |
| Dust Collector Bags              | DC2034 |
| Foot Pedal                       | FPRS   |



# 4.9 Switch Wiring Diagram

## 4.9.1 2034vx system

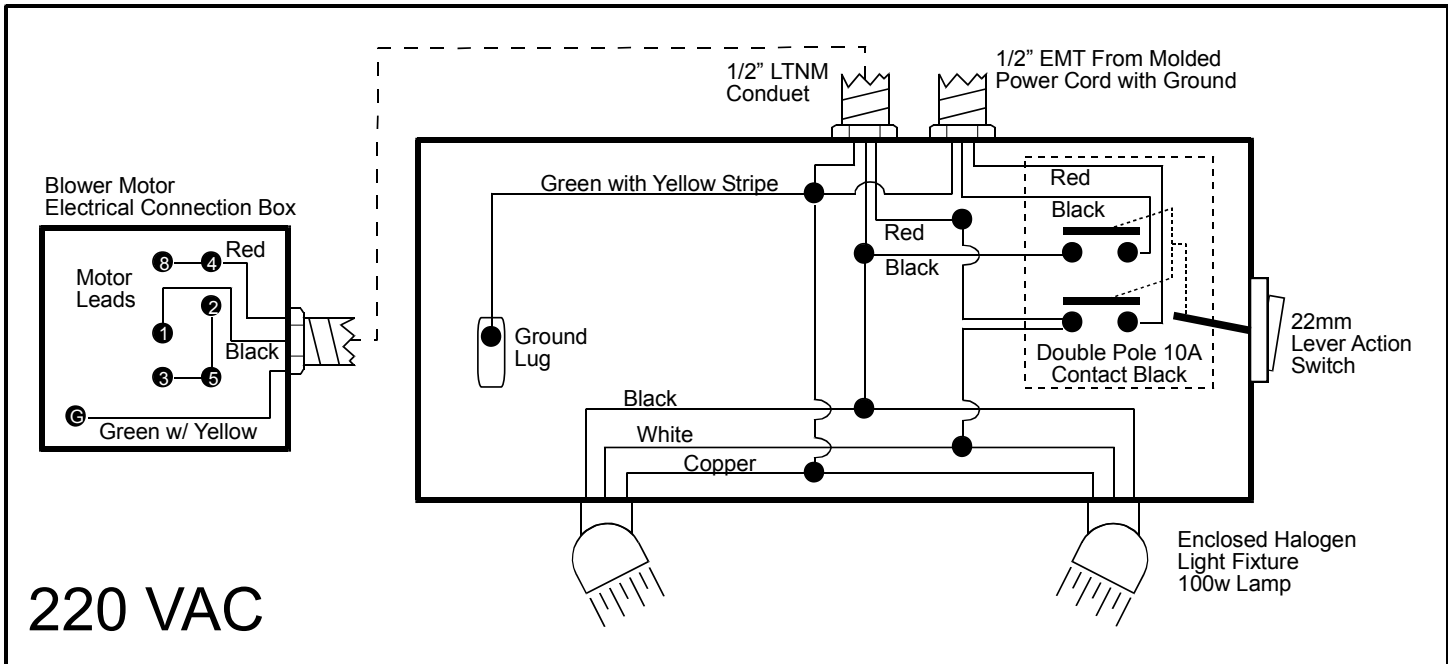
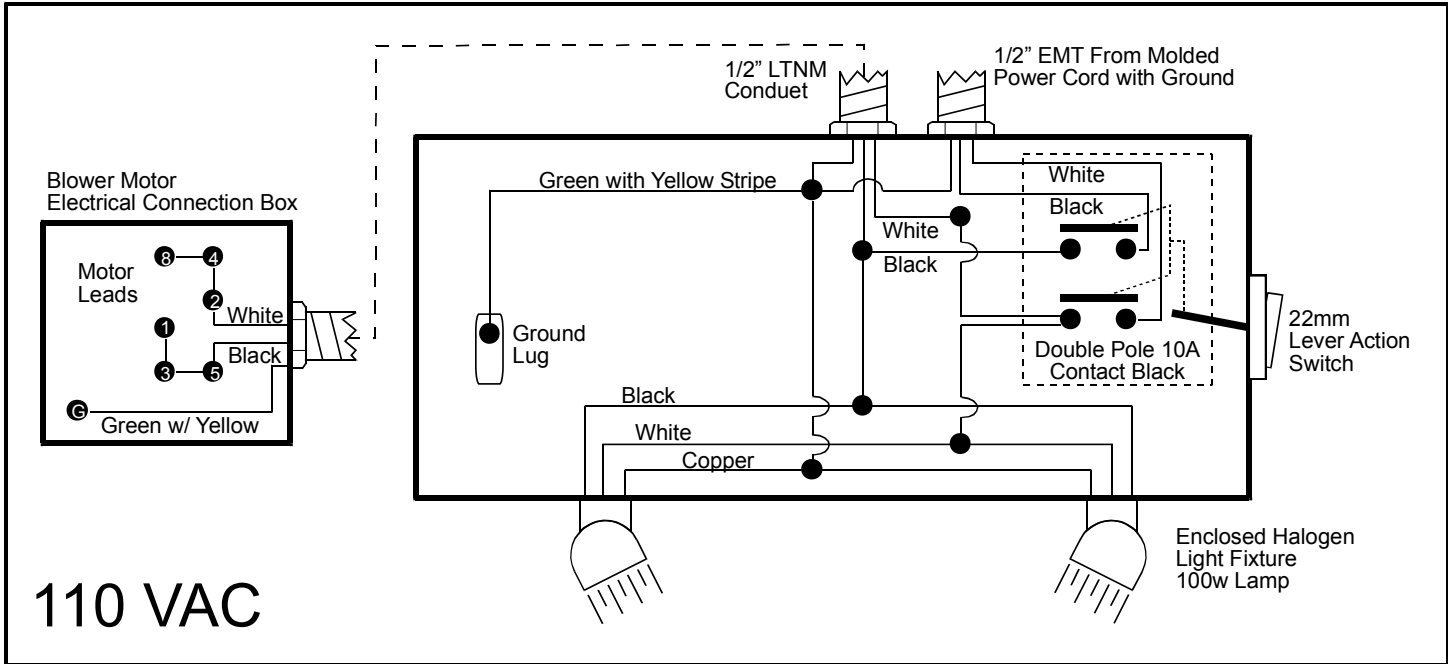

## 4.9.2 2034vx Adjustable

### 4.9.2.1 On some systems Blue and Yellow wires were Black and White.

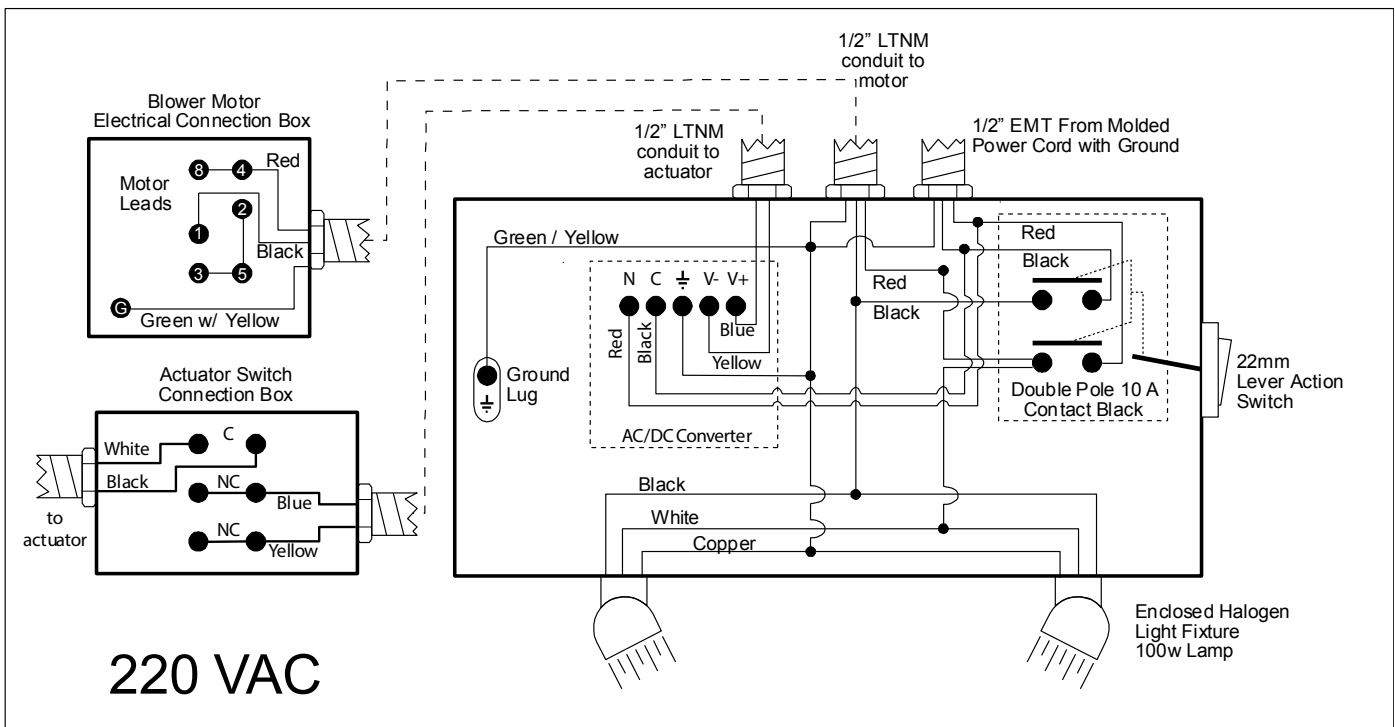
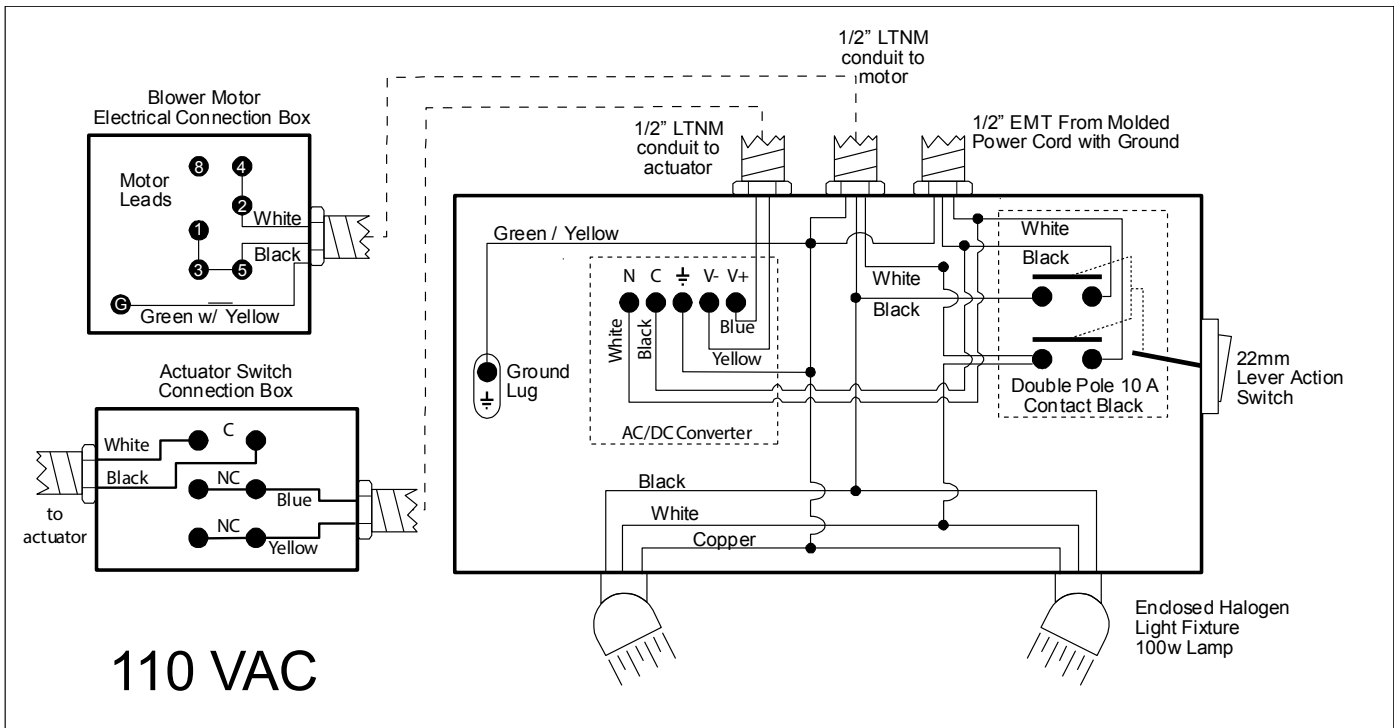



***RAYZIST***  
Photomask, Inc. ®

RAYZIST.COM | 800.729.9478

ORDER ONLINE: [WWW.RAYZIST.COM/STORE](http://WWW.RAYZIST.COM/STORE)